

Claude Lorrain
11/19/13 / JLD

"HOPES"
Acrylic on carton
70/100 cm

Charbel abou Zeidan

Belgian, born in Lebanon, I am fascinated by the idea of “ Positive immigration”.

Through my work, I merge origins and destiny.

I believe that immigration should have a positive impact on the society, so I paint hopeful and powerful words in Arabic.

Inspired by minimal architecture, subtle textures, pure and bold lines define my style. I am on a mission to fuse two rich and different cultures to create art that transcends geography, race and religion.

My work is dedicated for those who appreciate positivity, boldness, purity and geometry



"PEACE"
Acrylic on linen canvas
120/240 cm

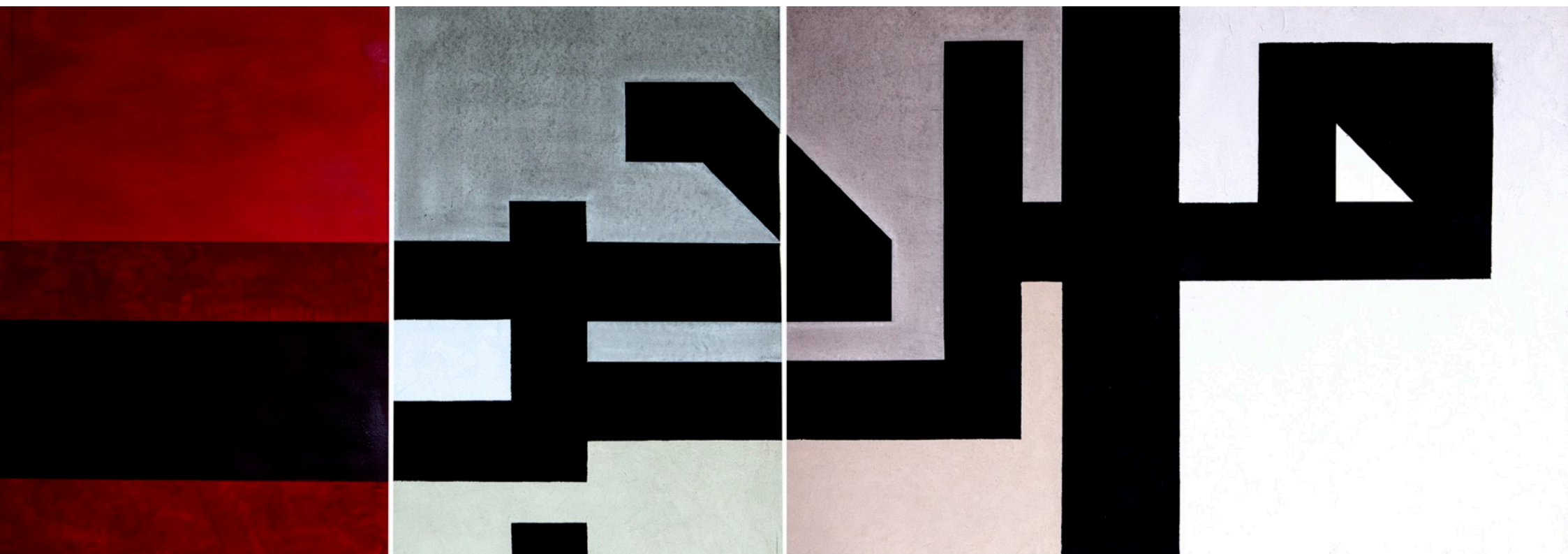

“HOPE/LOVE”

Triptych

Acrylic and ink on carton

50/70 cm 50/70 cm 100/70 cm

"Genesis Book, Carnet d'artistes" Studio Marant

A l'occasion d' Art Brussels et de l' Independent Art Fair, Stéphanie d'Orglandes et Julia Van Hagen présentent « 4 P I È C E S », la première édition de leur exposition itinérante, qui se tiendra au sein d'un hôtel particulier dédié à la collaboration artistique; L'Atelier Relief.

C'est dans le dialogue entre art contemporain et design que le Studio Marant présente une nouvelle collection de Genesis Book et fait appel à de nouveaux artistes qui interprètent à leur tour le livre blanc:

Lucien Murat, David Brogon et Stéphanie Rollin, Thierry Dreyfus, Garnier & Linker, Marc Buchy, Charbel Abou Zeidan, Elvire Bonduelle, Clara Champsaur, Julien Colombier, Lauren Collin...



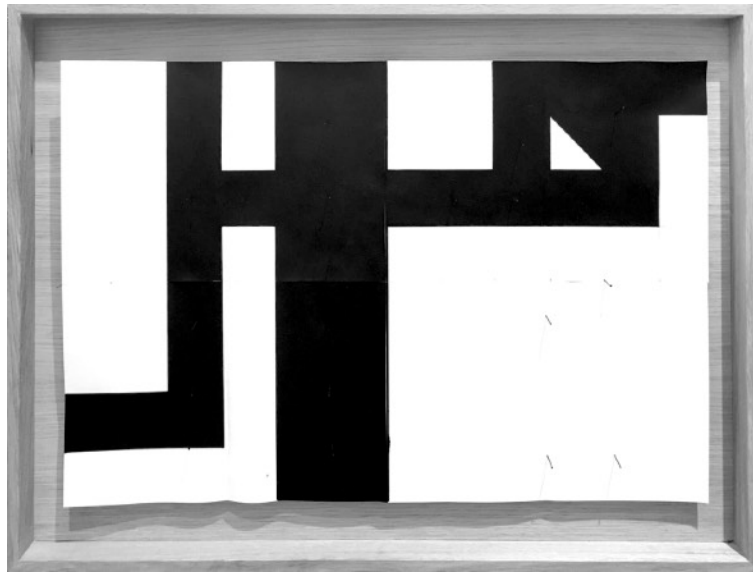

“PAIN/HOPE/LOVE”
Acrylic on sketchbook paper



"1914-2015 Actuele kunst tussen oorlog en Vrede"

Collective exhibition BUBOX, Kortrijk, Belgium

CHARBEL ABOU ZEIDAN (° Libanon 20 juni 1978)
Interieurarchitect, fotograaf, kunstenaar en modeontwerper.

Creatief natuurtalent Charbel Abou Zeidan studeerde interieurarchitect in Beiroet, Libanon maar ontwikkelde zich tot succesvol fotograaf, kunstenaar en modeontwerper. Hij werkte onder meer in de Parijse modewereld als hoofddesigner bij Elie Saab bekend couturier van koningshuizen.

Zijn grafisch werk draagt duidelijk de invloed van het kubisme (schilderkunst) en het brutalisme (architectuur). Charbel gebruikt een strak lijnenspel, evenwichtige en geometrische vormen die zich herhalen.

De sobere maar intrigerende grafieken van Charbel Abou Zeidan van zwarte acrylverf op wit of warmgeel papier passen perfect in de interieurs van vandaag. De uitgepuurde vormen zijn abstracties van de lettertekens van woorden uit het sierlijke Arabische schrift. Hij vertrekt van het woord 'oorlog' maar wendt zich resoluut af van alle negativisme. Hij focust op het menselijke, mooie en waardevolle in het leven: 'hart, liefde, geluk, vrede...'. Hij presenteert zijn positieve boodschappen soms in een drieluikje maar soms op groot formaat – alsof hij de betekenis ervan wil uitschreeuwen.
www.lebrahc.com

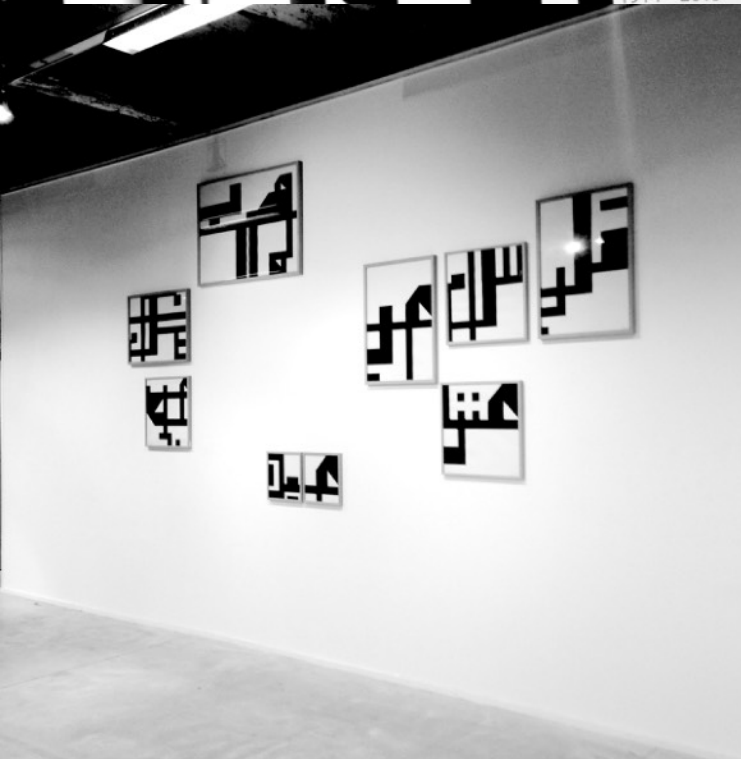
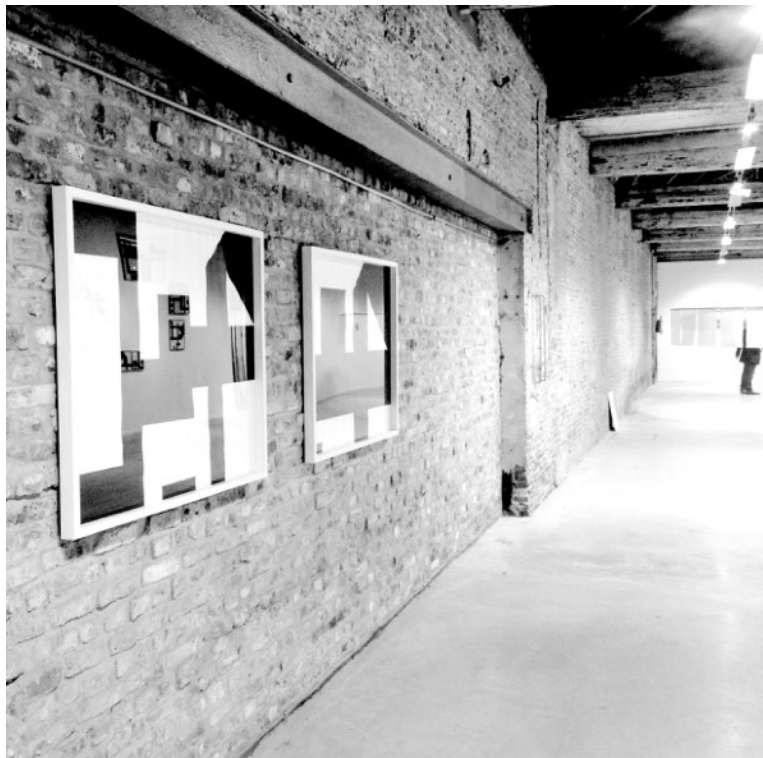

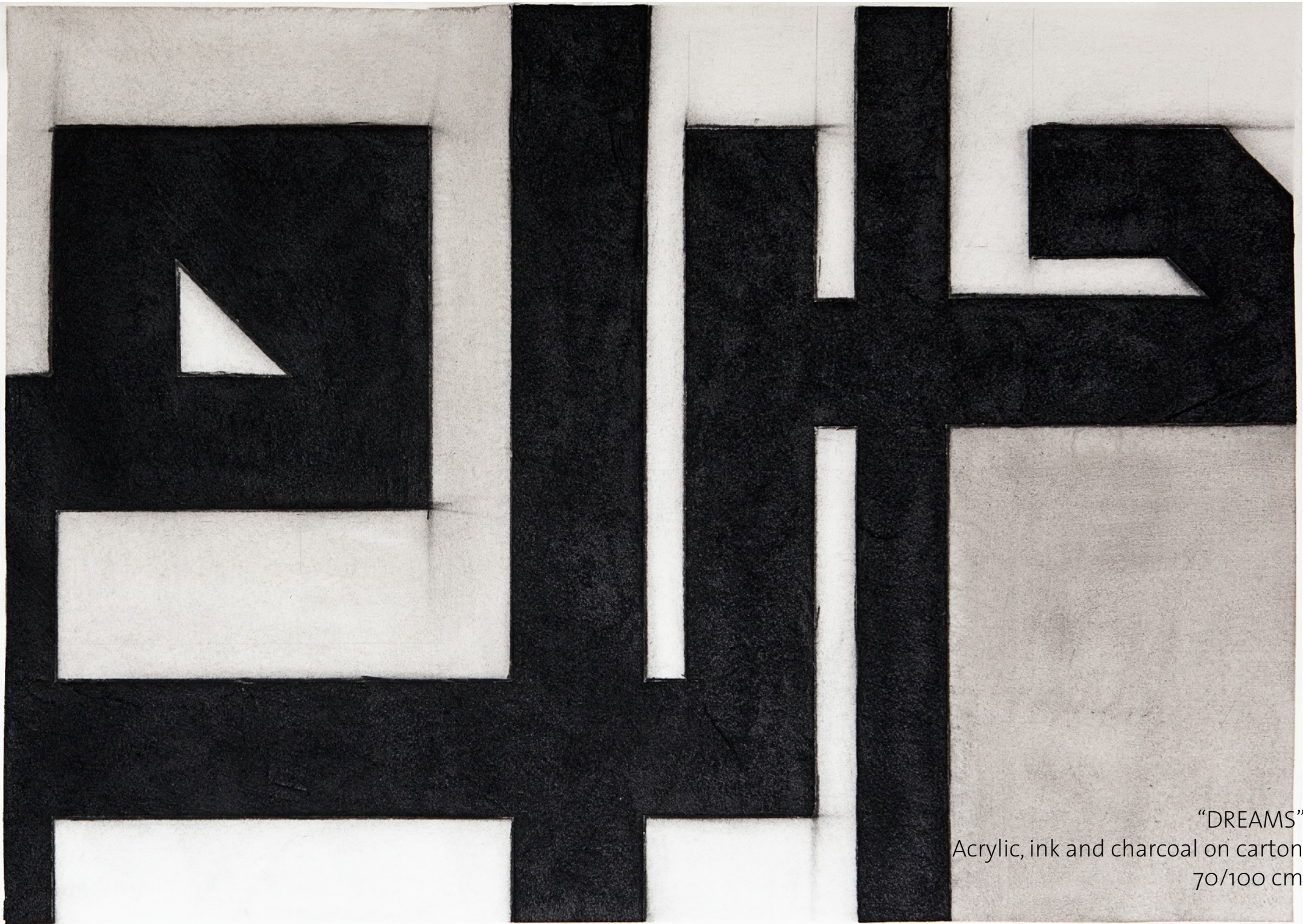

"DREAMS"
Acrylic, ink and charcoal on carton
70/100 cm



“LOVE”
Acrylic and ink on carton
70/100 cm

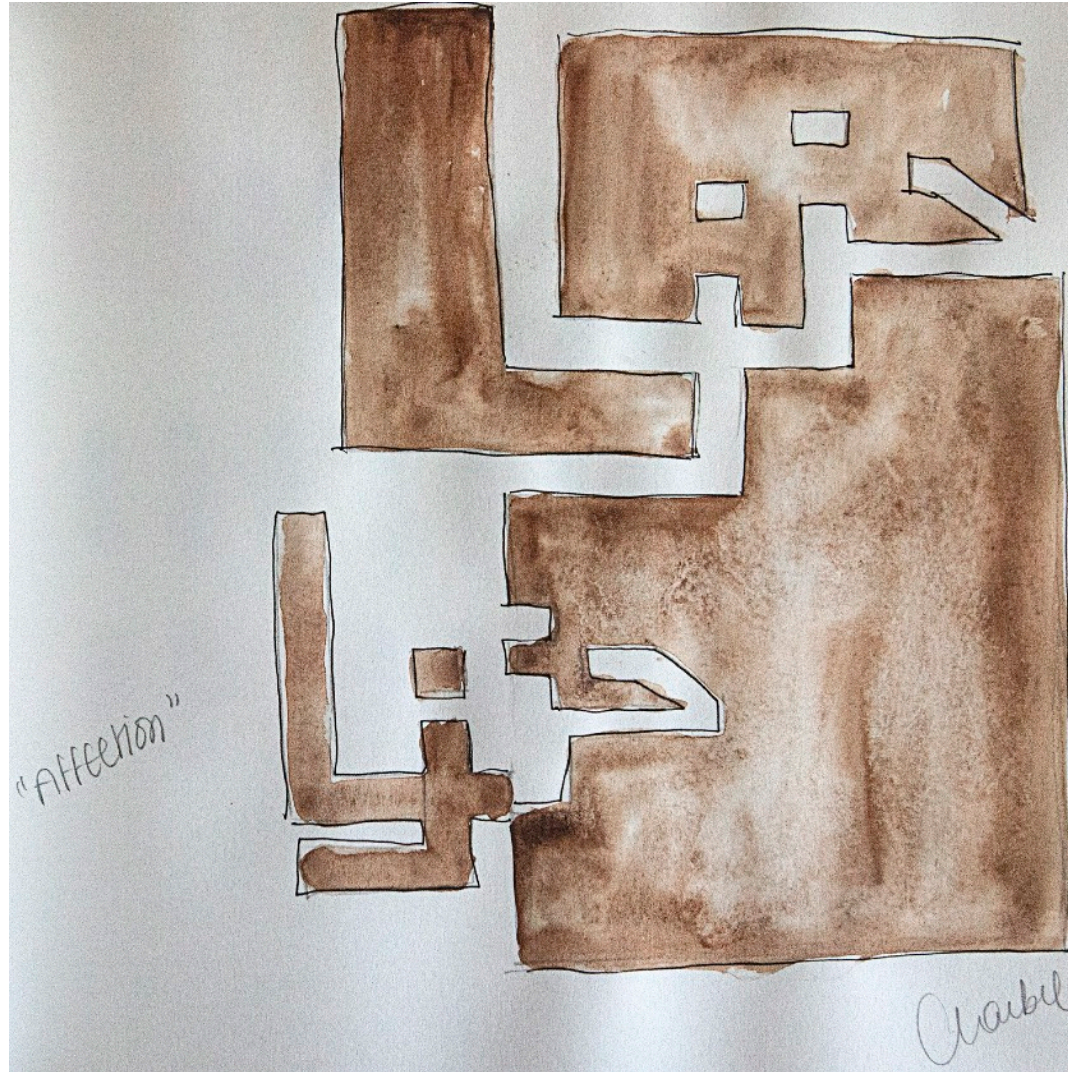

"AFFECTION"
Study
aquarelle on sketchbook
25/25 cm

"Pictural Architecture" Atelier Relief

Collective exhibition, 1050 Brussel, Belgium

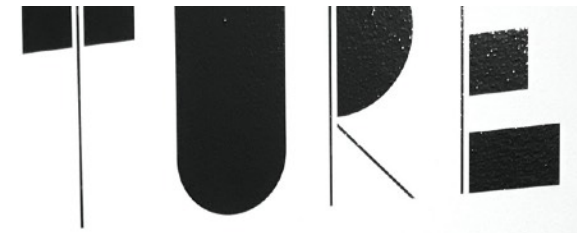

Serge Najjar

Tim Furzer

Olivier Truyman

**Charbel Abou Zeidan
& Zoom Architecture**

**from June 19th
to July 22nd 2016**

#atelierrelief

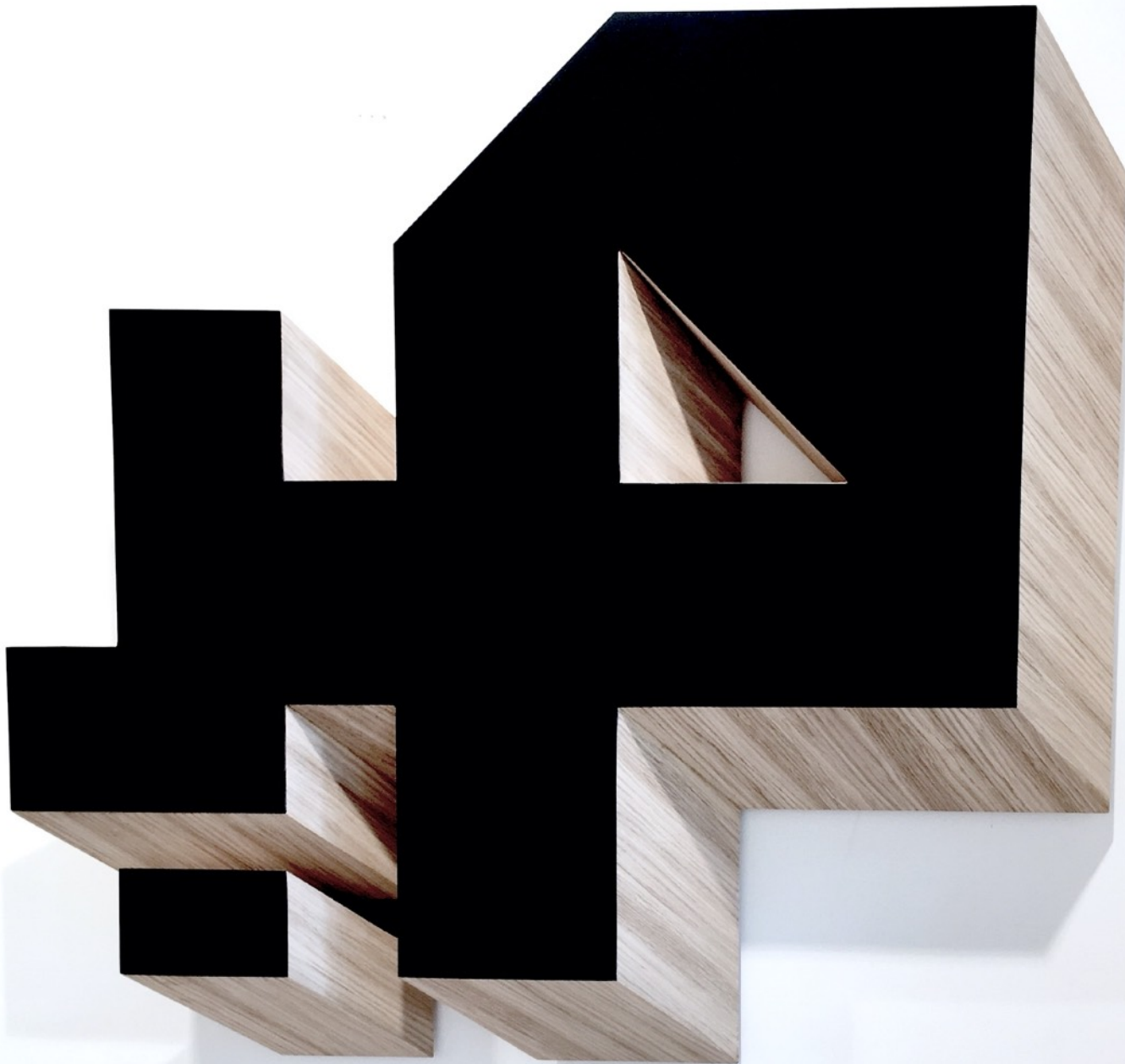

“LOVE”
Oak wood
100/100 cm

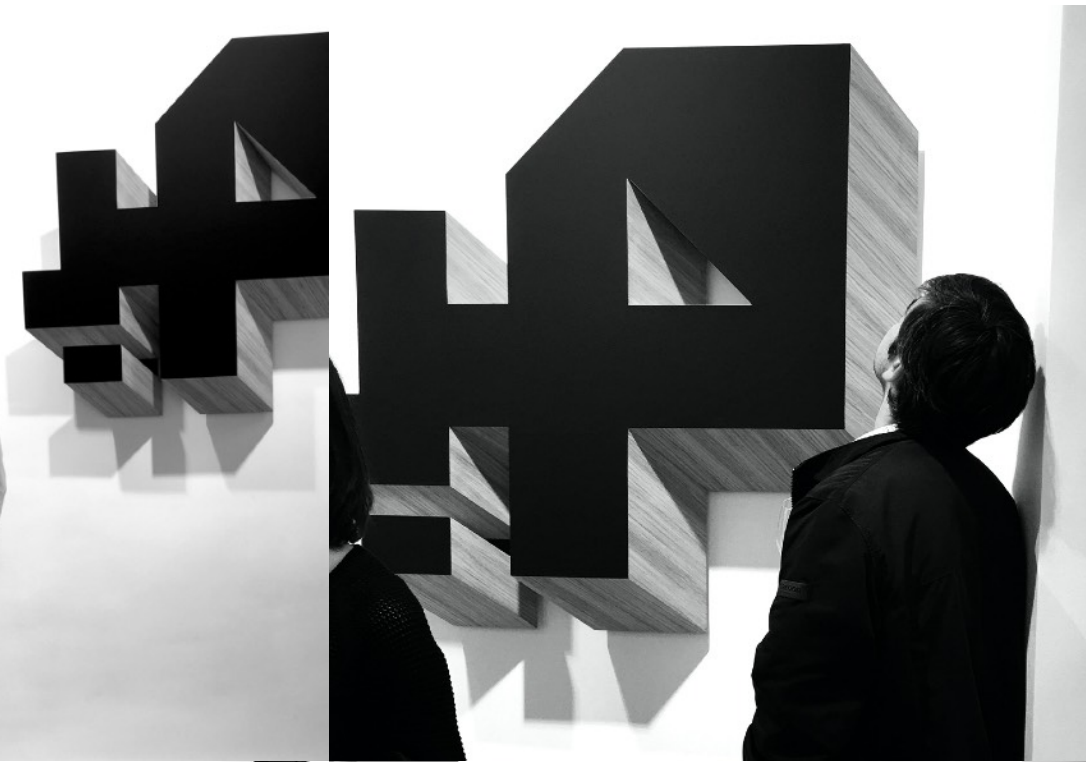

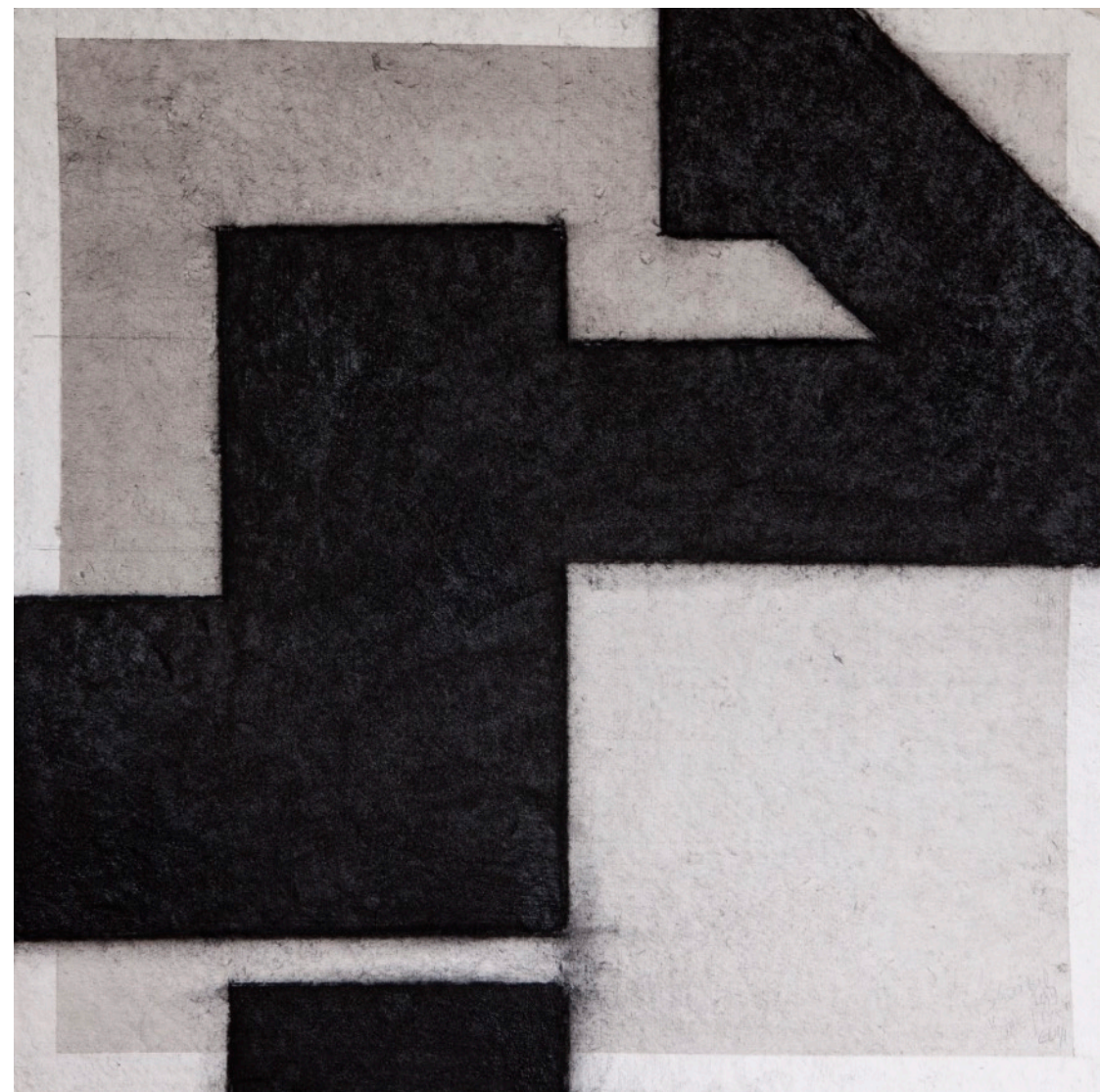

"LOVE"
Ink and charcoal on carton
50/50 cm

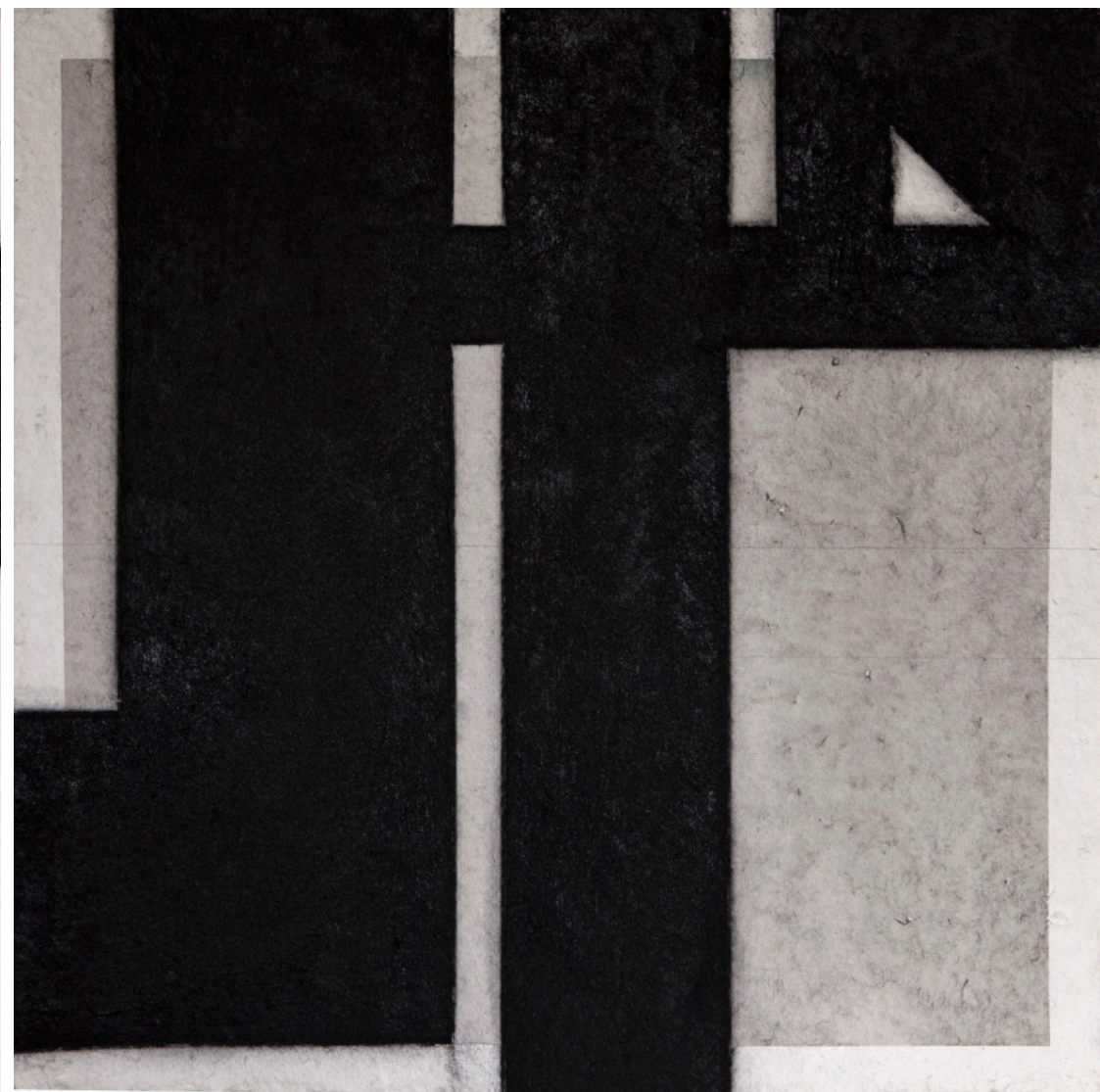

"HOPE"
Ink and charcoal on carton
50/50 cm



“LOVE”
Ink and charcoal on carton
50/50 cm

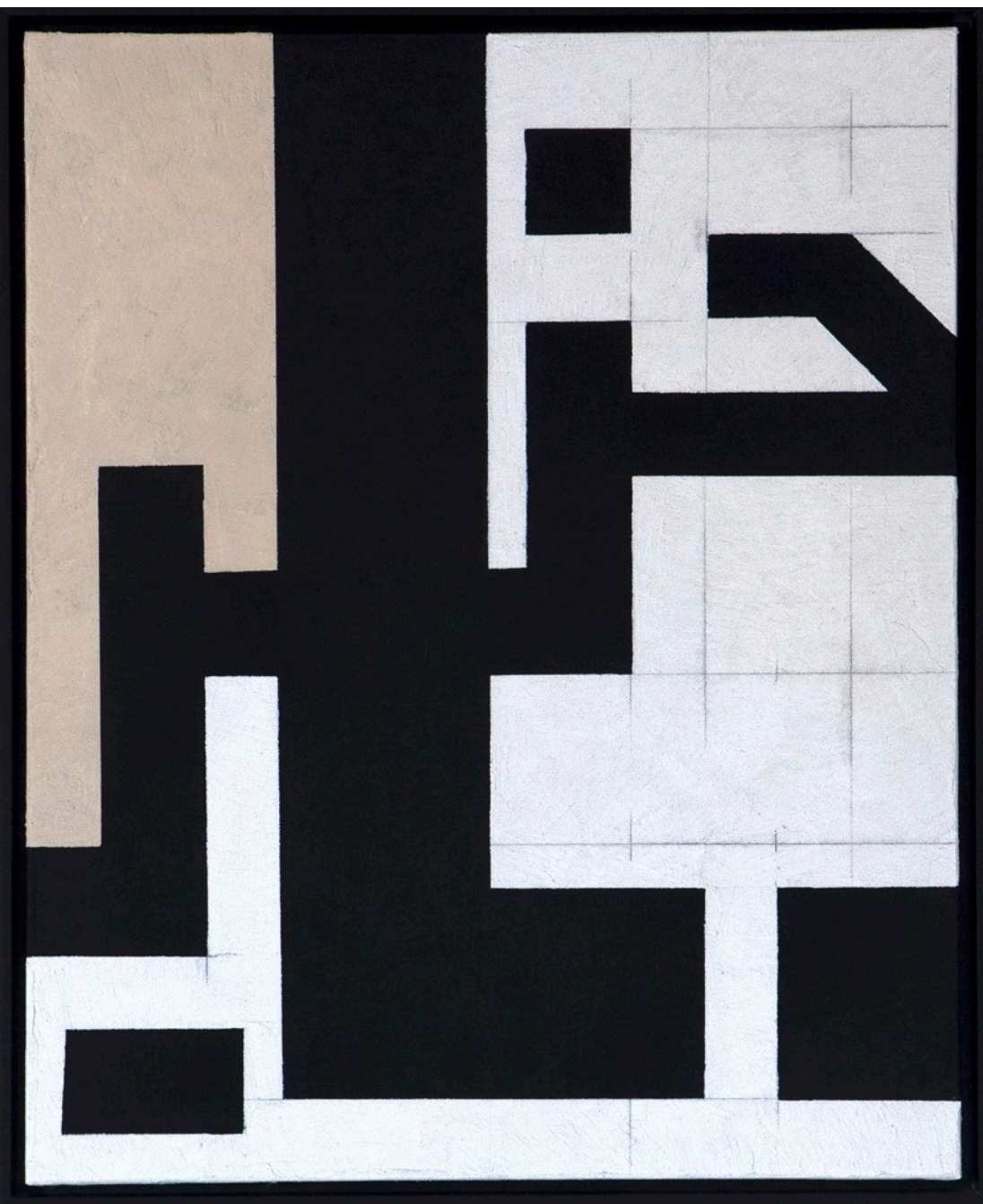

"NOSTALGIA"
Acrylic on canvas
70/85 cm

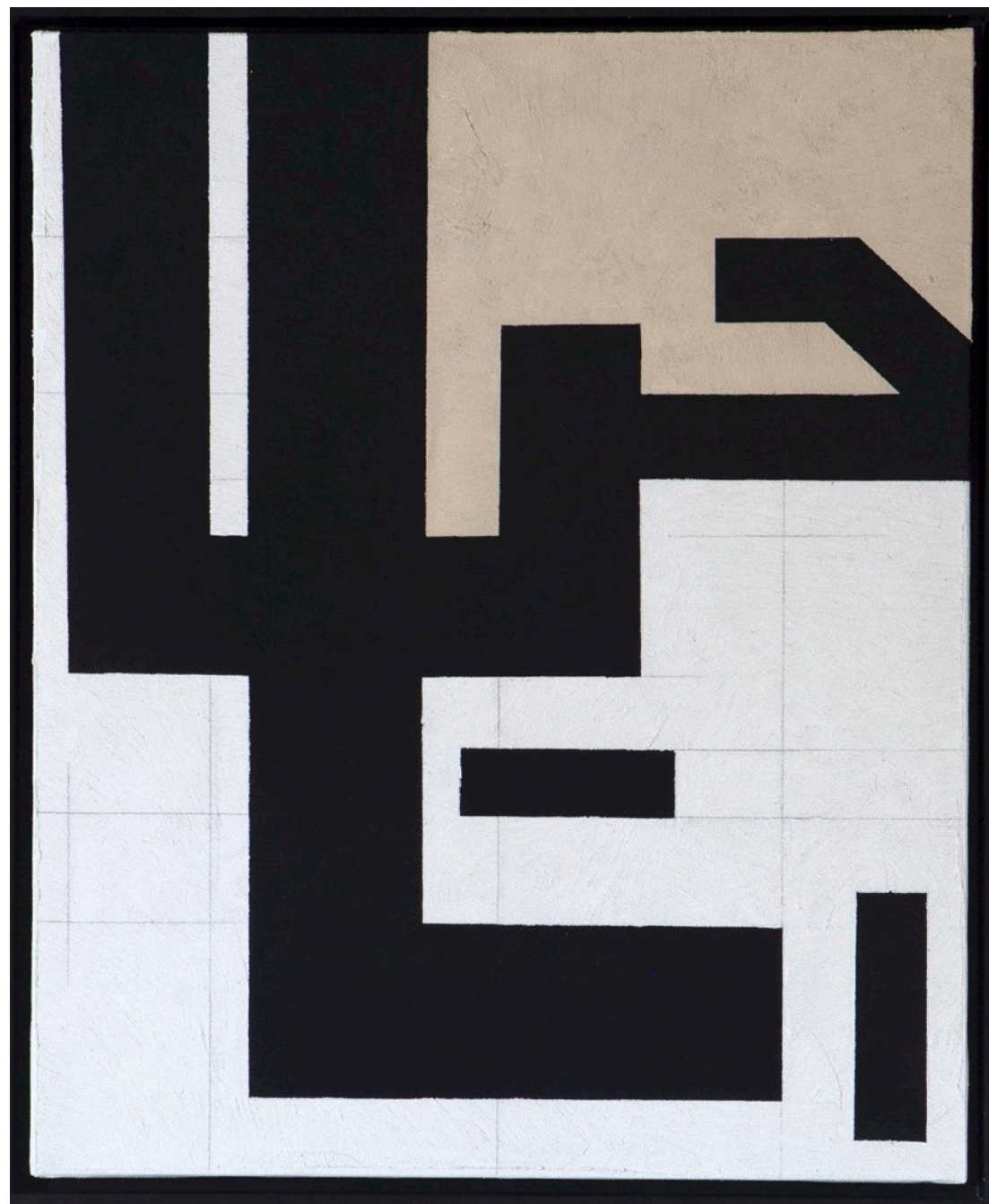

"LIFE"
Acrylic on canvas
70/85 cm

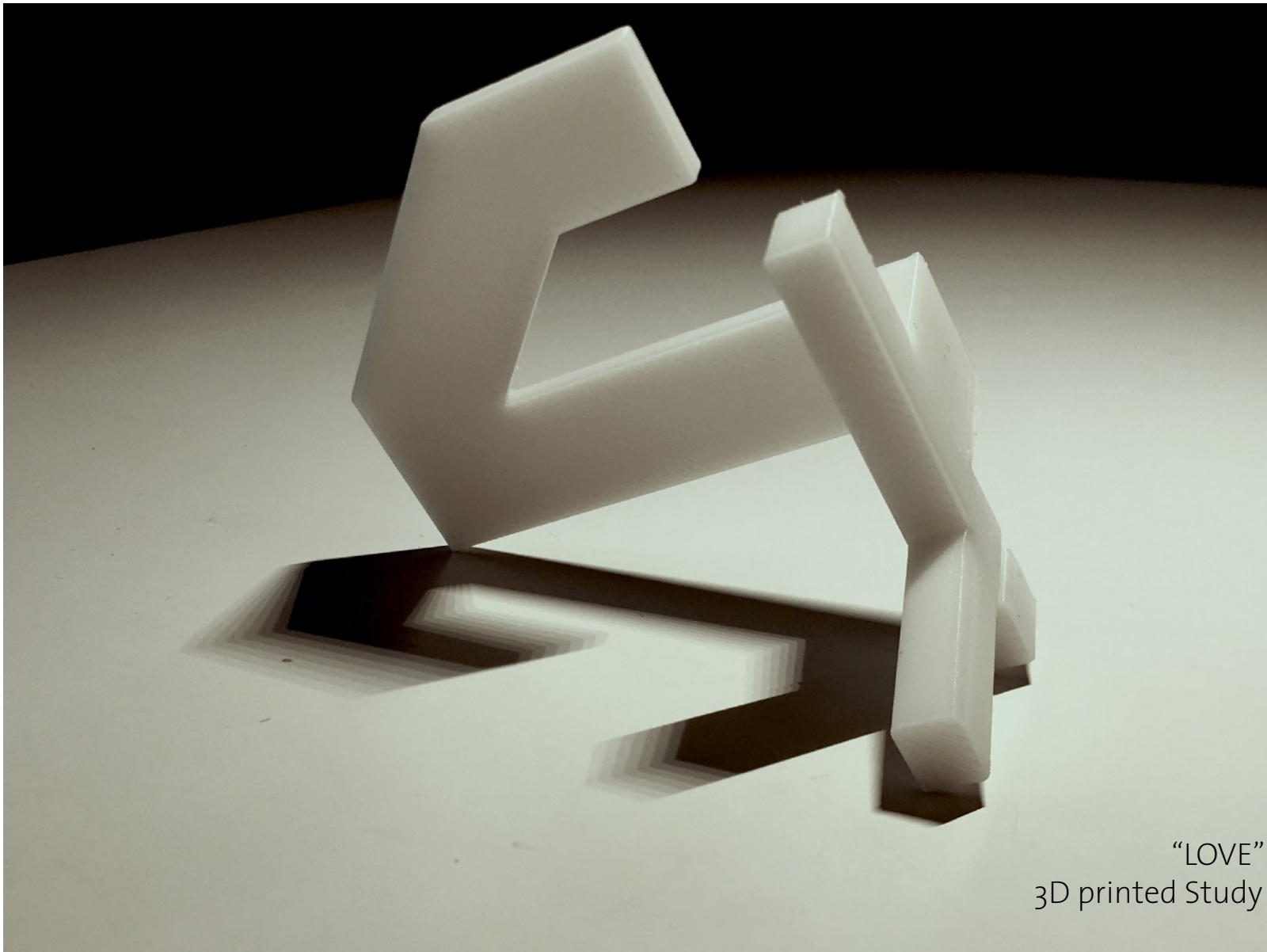

"LOVE"
3D printed Study

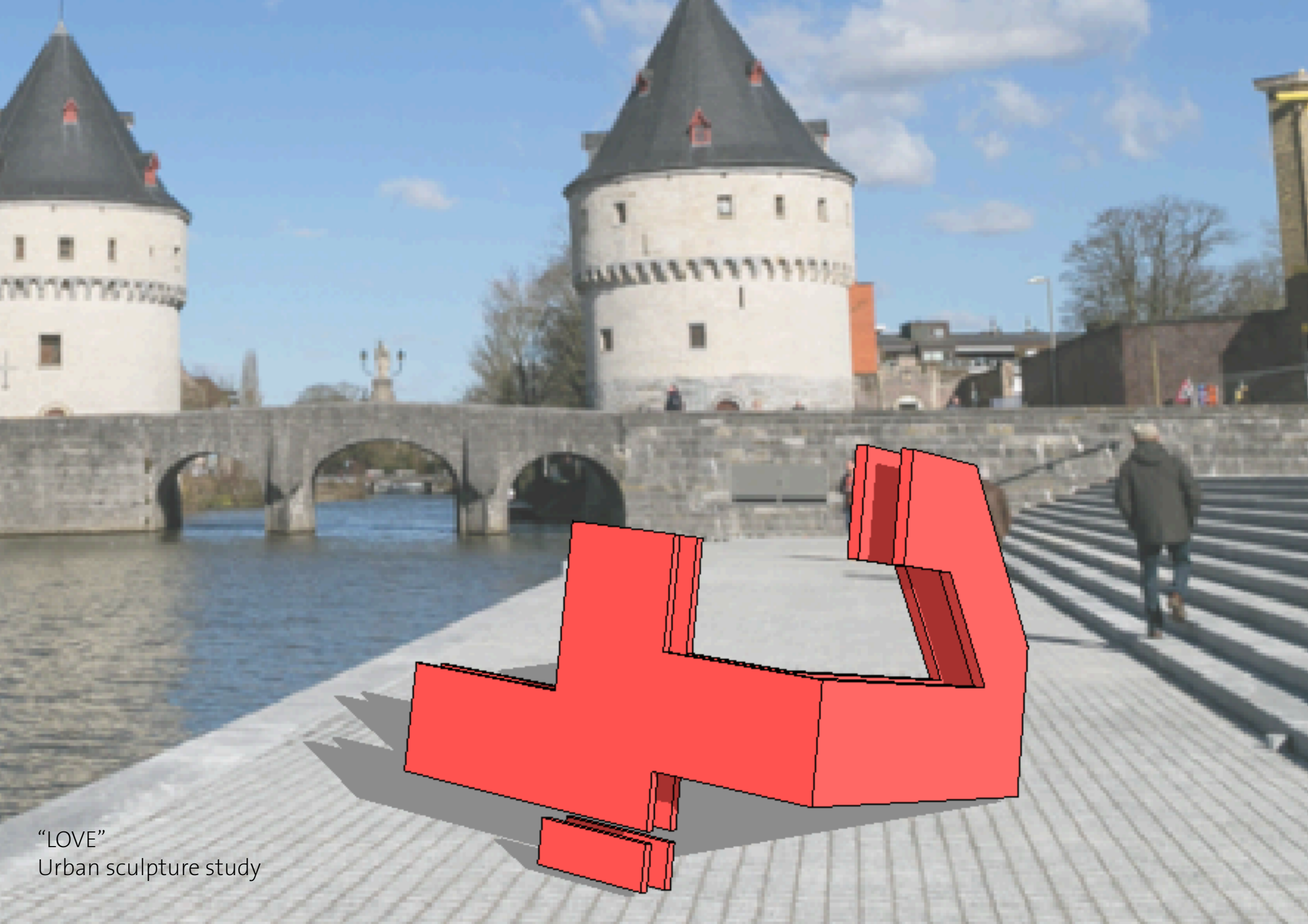

“LOVE”
Urban sculpture study

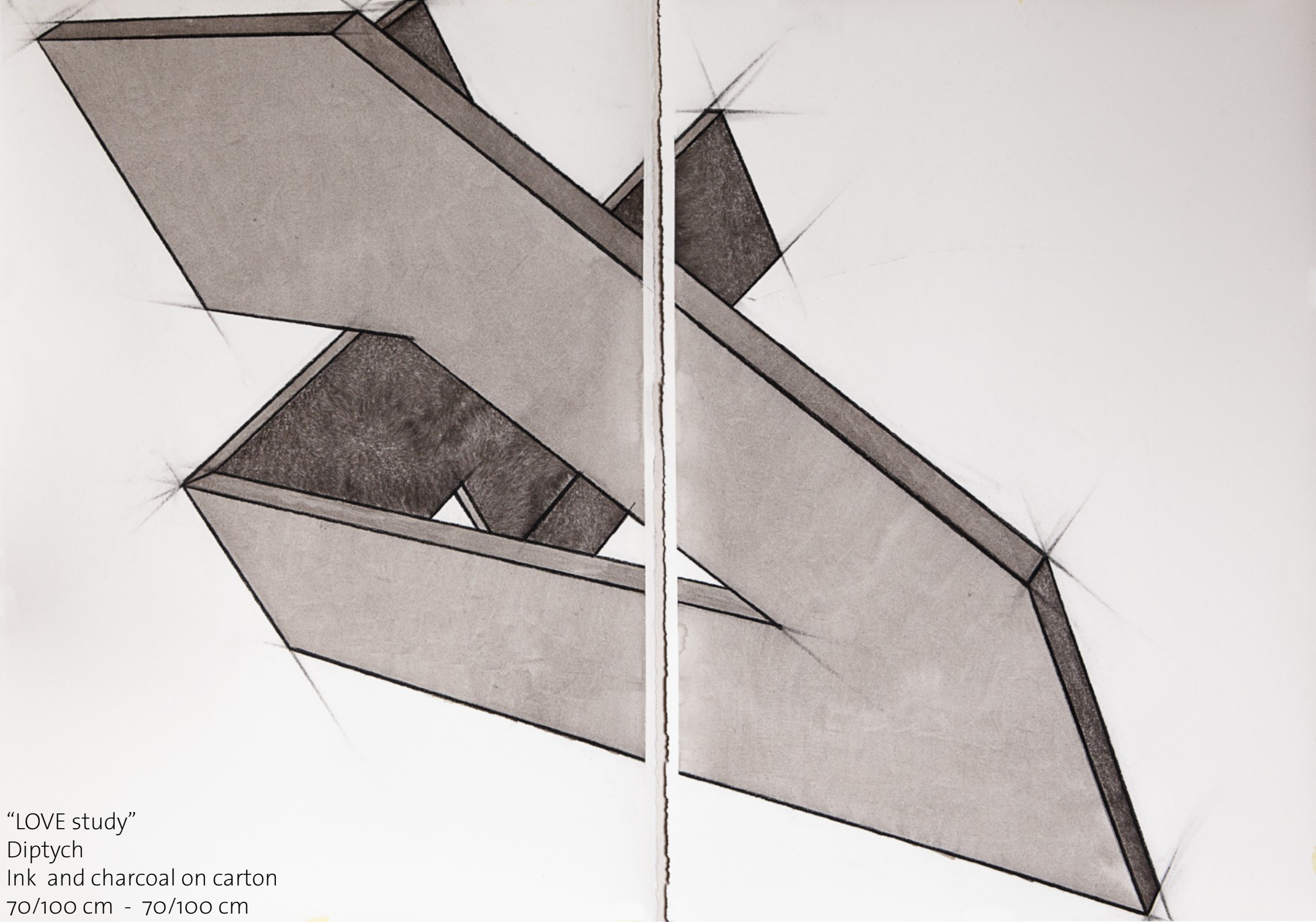

“LOVE study”
Diptych
Ink and charcoal on carton
70/100 cm - 70/100 cm

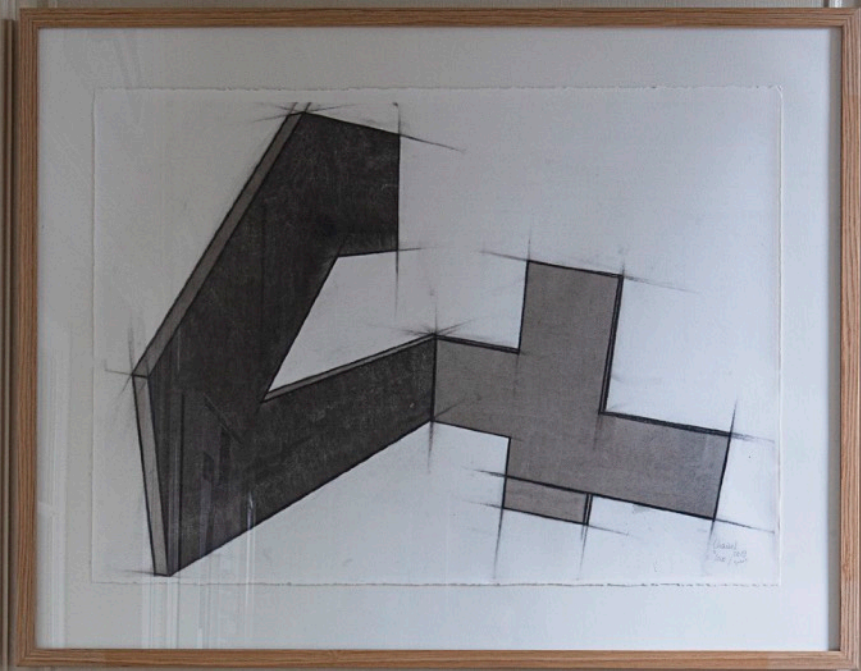

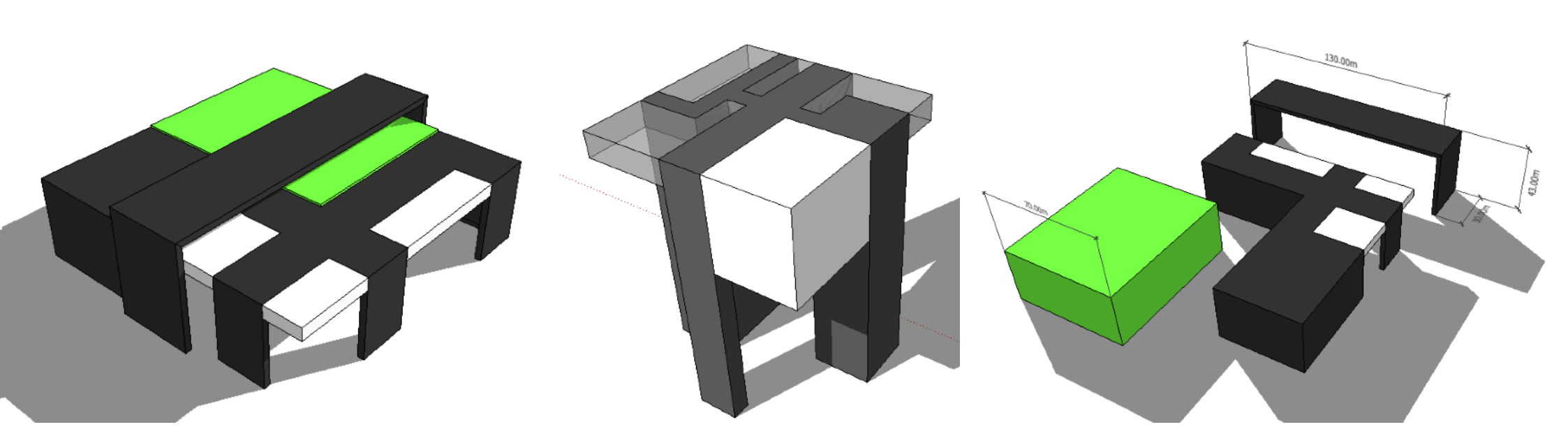

Furniture studies

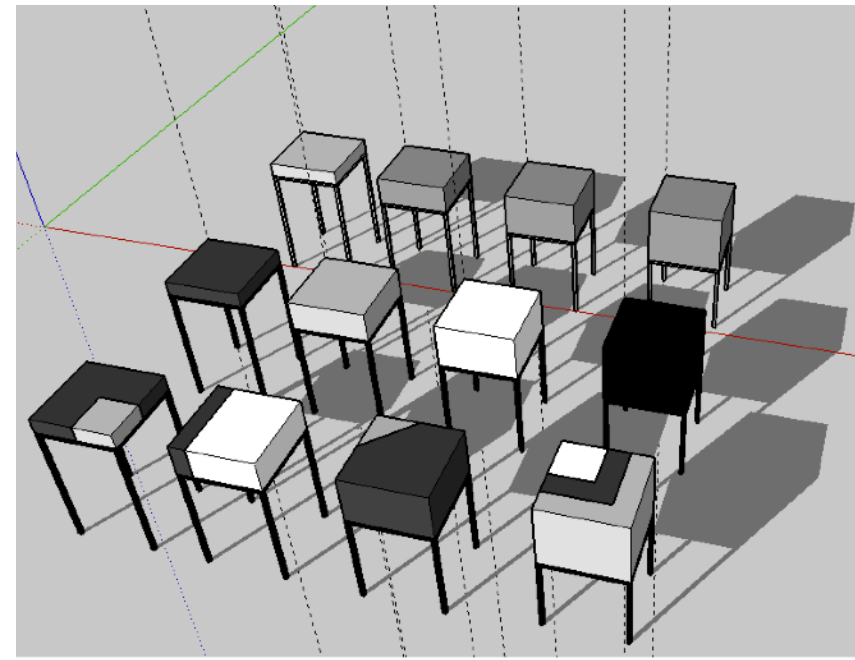
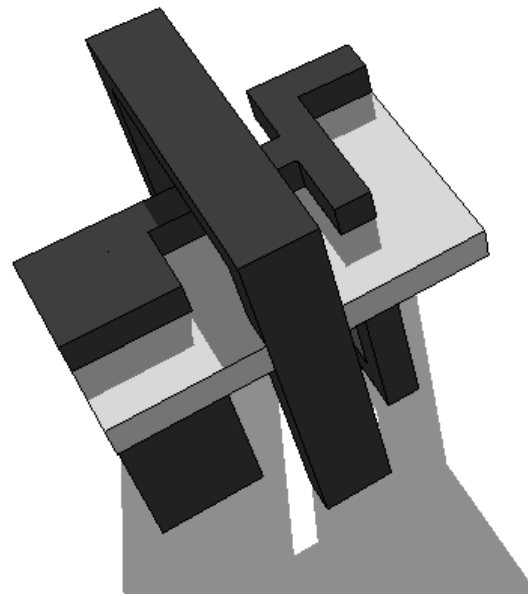
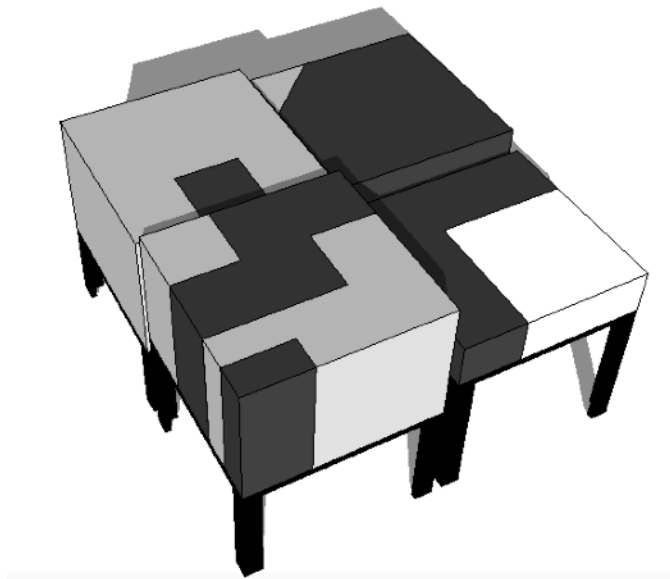

“LOVE study”
Ink and charcoal on carton
70/100 cm

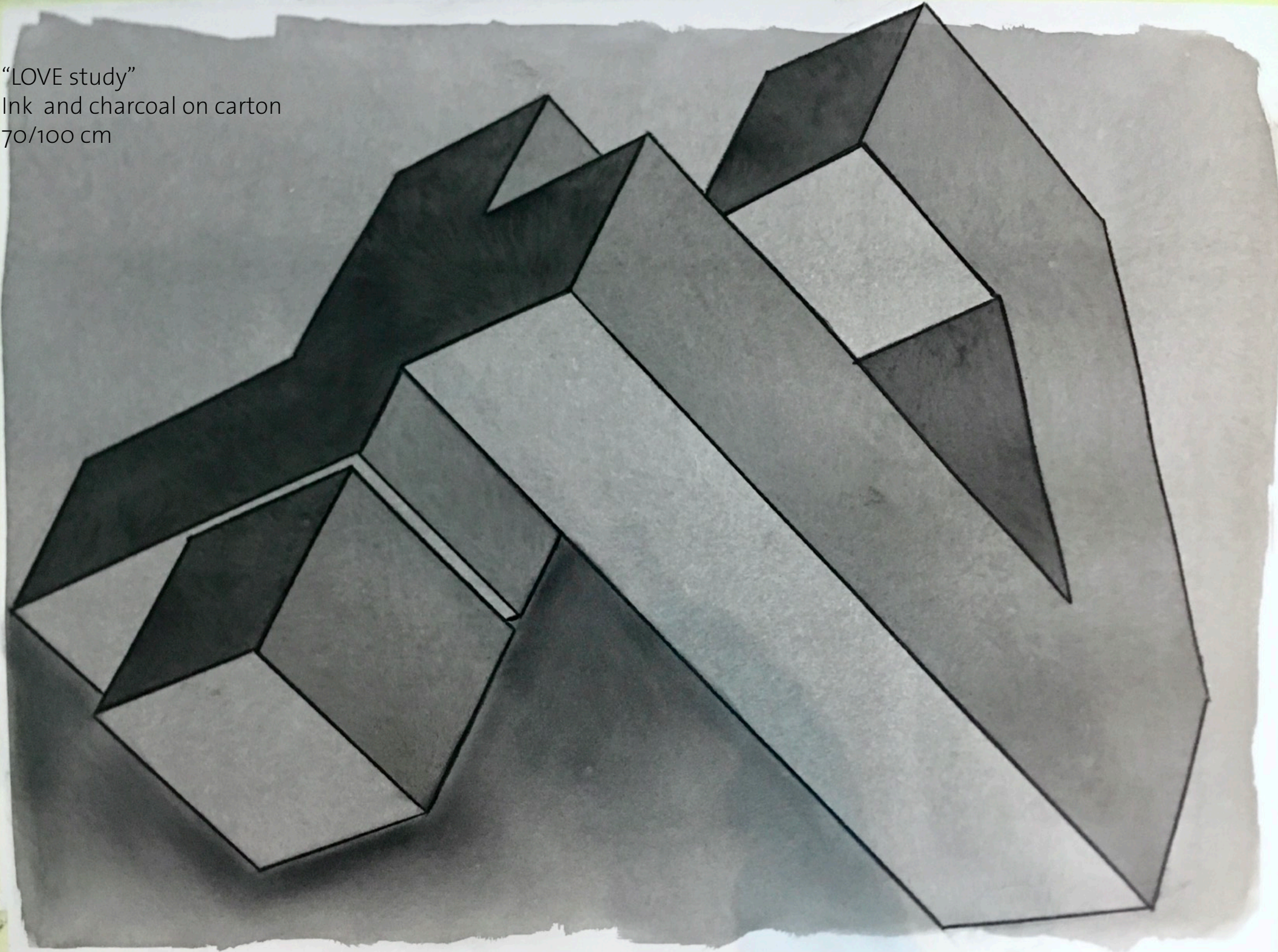

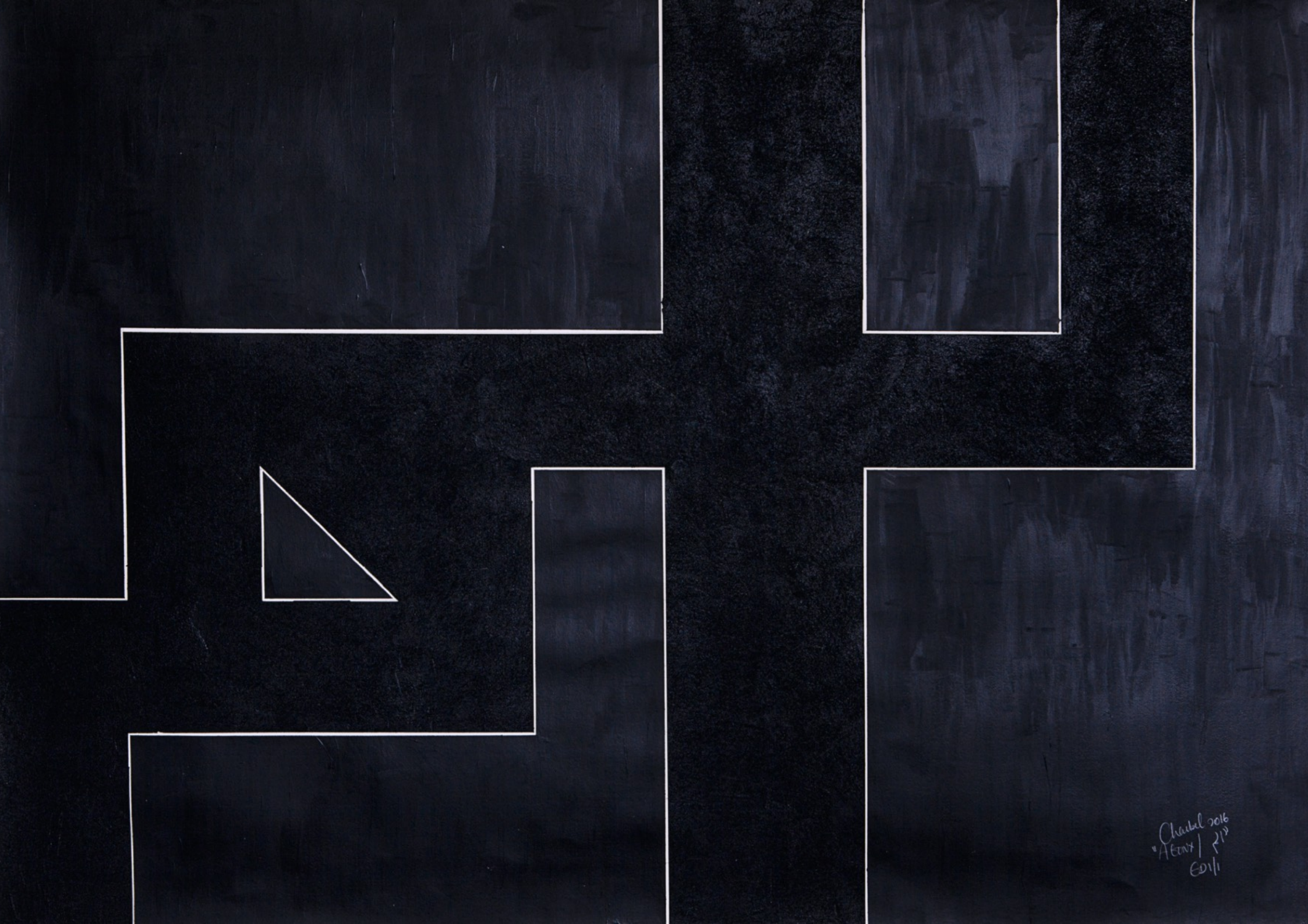

Charbel 2016
Arenx / 21
E01/1

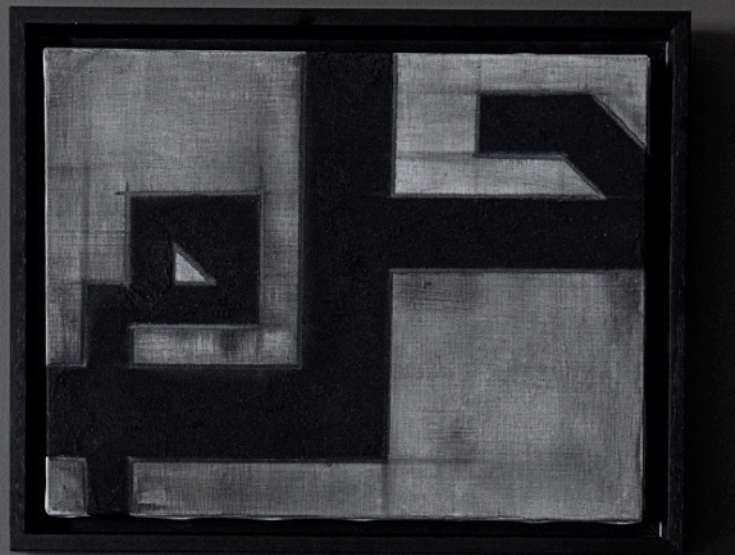

"DREAM"

Acrylic and charcoal on canvas
30/40 cm



“PEACE”
Wool rug
300/370 cm

“HOPES”
Acrylic on linen canvas
90/130 cm

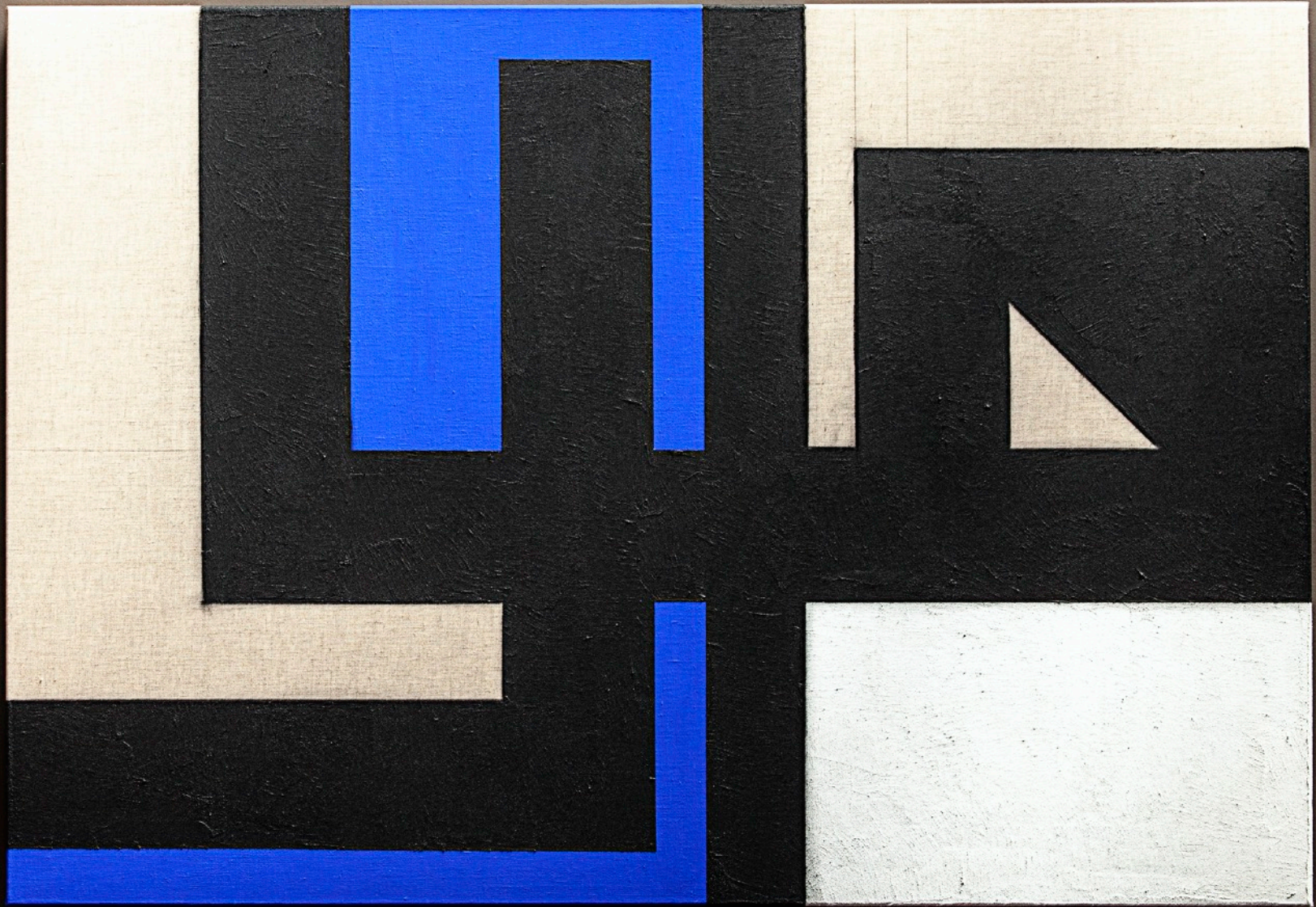

Charbel abou Zeidan - Tel: +32 479 981654 - instagram: charbel.abouzeidan - e-mail: charbelabouzeidan@gmail.com - Kortrijk, Belgium